

Installing timber windows

Timber windows produced by members of the British Woodworking Federation are accurately designed and manufactured using the best available techniques to produce performance rated products. The way in which they are installed, however, can affect their performance.

Good installation practice avoids damage, maintains quality and saves money.

Windows are available as joinery items supplied with a primer or stain base coat for site glazing and finishing, as factory glazed components requiring site finishing or as a factory glazed and fully finished windows.

Delivery and storage

See BWF's leaflet "Care of timber windows on site" for advice on site storage and handling. Prefinished and preglazed units should be brought to site as close to installation time as possible.

Protection

With prefinished and preglazed windows the manufacturers' protection should be left in place unless this interferes with the integrity of the DPC and seals.

More care is necessary when fitting prefinished units.

Any timber which is cut during the course of installation must be treated with a compatible preservative.

Note: Cutting or damaging a window may invalidate the manufacturers guarantee

Forming Openings

Windows can be fitted either during the course of construction or fitted into pre-formed openings at a later stage.

A tight fit of adjacent materials should be avoided where there is danger of distortion of the frame. Side tolerances however should not exceed 10mm on each side.

When not building-in, openings can be formed using either proprietary templates or site constructed templates. These templates should produce openings that are in the order of 10mm to 20mm larger than the actual window size.

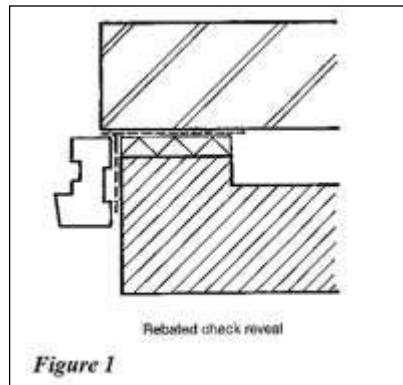

Figure 1

In exposed conditions consideration should be given to using a rebated check reveal (Figure 1)

Fitting

DPCs should be fitted as the construction proceeds. This can be achieved either by fixing the DPC to the frame prior to building in or by fitting the DPC into the structure when making pre-formed openings. In the latter case it is often convenient to use wider DPCs than needed (Figure 2).

Avoid forming a cold bridge when fitting windows.

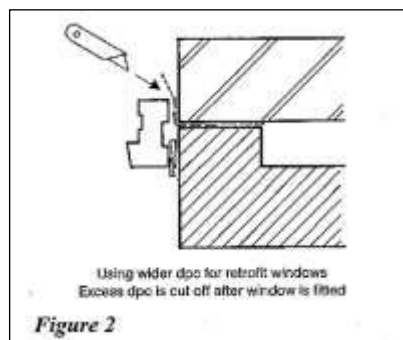

Figure 2

Support

Windows should be supported on durable packings at a maximum of 150mm from each jamb and beneath mullions. The window should be fitted level and plumb (Figure 3). When building-in, continuous support at sill level can be provided by a mortar bed.

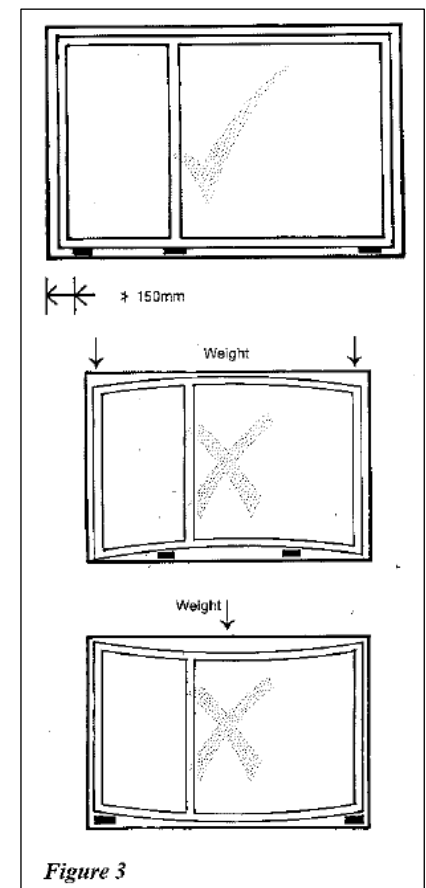

Figure 3

Support for the frame should be such as to prevent distortion and should not damage any protection or finish.

Side packings should be located where fixings occur and fitted without distorting the frame.

Particular care is necessary when providing packings to sliding sash windows where even minor distortions can prevent movement of the sashes or introduce excessive clearance to sashes (Figure 4).

When fitting packings it is advisable to check the operation of all types of windows prior to final fixing.

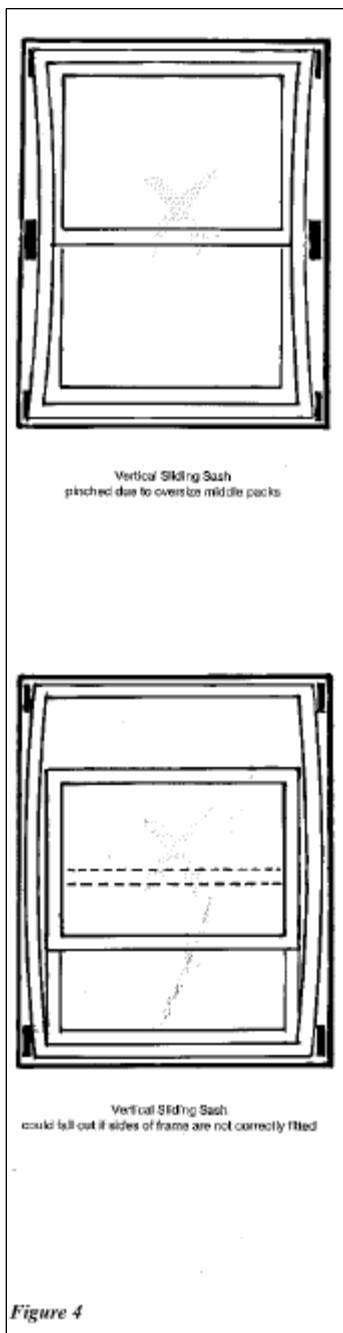

Fixing

Side fixings should be provided at 150mm from top and bottom of frame and a maximum 450mm

between c/s. Where a window exceeds 1800mm in width or is formed with two or more units, fixings should be provided at head and sill (Figure 5).

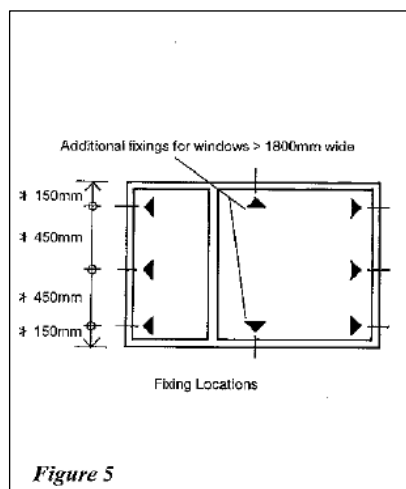

Special requirements may be necessary when fixing windows into preformed openings.

Unless internally fitted fixing clips are used (Figure 6) it will be necessary to fix through the frame. Where possible, choose unobtrusive locations. If a cavity closer is used refer to manufacturers' recommendation.

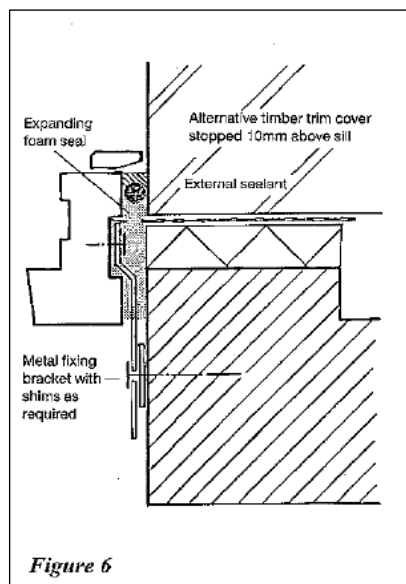

Purpose made nylon frame fixings are available. These utilise the same diameter hole through the timber as well as the substrate. The fixing is usually supplied complete with the screw.

Alternative fixings include a proprietary screw device, which enables the window to be adjusted in

position on the screw fixings (Figure 7).

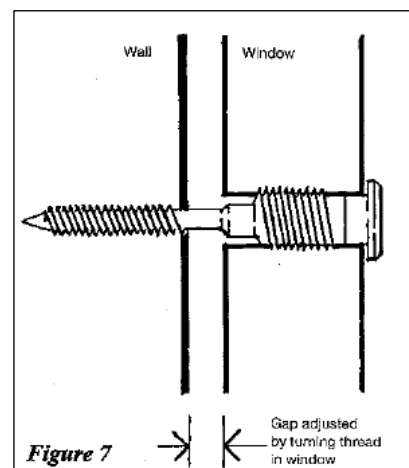

Sealing

To prevent air infiltration between the window and adjacent wall the gap between the window and wall should be sealed. A polythene backed sealing strip can be fitted prior to building-in or alternatively an expanding foam seal or mineral wool can be fitted after building-in is completed.

These will expand after a period of time to fill the gap (Figure 6).

An additional seal can then be provided by silicone or polysulphide based sealant.

Alternatively a timber cover strip can be provided which should be fitted over the foam seal. This strip should be cut 10mm short of the sill. This method permits any moisture which reaches the foam seal to escape.

Decoration

Finishing should be carried out in dry weather using good exterior quality materials in accordance with the manufacturer's instructions (see 'Care of timber windows on site' for advice).

Note: Whilst every effort has been made to ensure the accuracy of advice given, the federation cannot accept liability for loss or damage arising from the use of the information supplied in this publication.

This document is due to be updated in 2014 in line with revisions to BS 8213-4

A list of BWF window manufacturers is available from www.bwf.org.uk